

Workplace Health and Safety Bulletin



Servicing Tires Safely

Tire and wheel assembly failures

Inflating a truck tire may seem like a simple, non-hazardous task until one realizes that a 20-inch tire inflated to 100 psi can contain up to 40,000 lbs of explosive force. A properly maintained tire can handle this amount of pressure but one that has been used while flat or under-inflated can present significant risks. The ply cords in the sidewalls may have lost their strength and have become permanently damaged. One or more of the weakened cords may then break during inflation, placing more stress on adjacent cords. Cord failures then continue until a rupture occurs and the sidewall “zipper” open.

Particularly serious are events caused by the explosion or violent separation of parts of multi-component wheel assemblies. Blowoffs, the sudden, violent springing of tire lock rings, rims or flanges from tires being assembled, are the main hazard. Blowoffs usually happen when tires have just been mounted on their rims and are being inflated. The cause is generally incorrect positioning of tire fastenings but may also include out-of-true rims and defective component parts.

Blowoffs usually happen when tires have just been mounted on their rims and are being inflated.

Recent incidents

In recent years Workplace Health and Safety has investigated two serious incidents and two fatalities (see references at end of Bulletin). In all cases the workers involved were inadequately trained to safely service the tire and/or were not using proper safety equipment. Two workers sustained serious injuries when struck by a tire that zippered,

one was killed while inflating a tire that contained a mismatched tire and rim, and another worker was killed when a multi-piece rim separated during tire inflation and the components struck him.

Requirements of the *OHS Code*

Worker competency and safety manuals

Section 193 of the *Occupational Health and Safety (OHS) Code* presents the rules that apply to employers and workers involved in tire servicing. Employers must ensure that only competent workers – workers who are appropriately trained, qualified and with sufficient experience to do the work safely – are allowed to service, inspect, disassemble and reassemble a tire or tire and wheel assembly.

If a worker is not competent to perform this work, the worker must be under the direct supervision of a worker who is competent. All of this work must be performed according to the manufacturer's specifications or instructions. Workers performing this work must be trained and understand how to properly inspect and safely service tire and wheel assemblies.

The employer must also make sure that the tire manufacturer's inspection and servicing requirements are followed. Truck tire servicing manuals and videos are available from most manufacturers. The manuals must be kept on hand and readily available so that all workers can access them.

Only competent workers are allowed to service, inspect, disassemble and reassemble a tire or tire and wheel assembly.

Make sure the tire manufacturer's inspection and servicing requirements are followed.

Split-rim or locking ring wheel assemblies

Tires mounted on split-rim or locking ring wheels (see Figure 1) must be inflated in a safety cage as shown in Figure 2 or be suitably restrained to contain flying parts in the event of tire rupture or component failure. Some manufacturers recommend partial inflation in a safety cage and full inflation once the tire and wheel assembly is mounted on the vehicle axle.

Figure 1 Example of locking ring rim

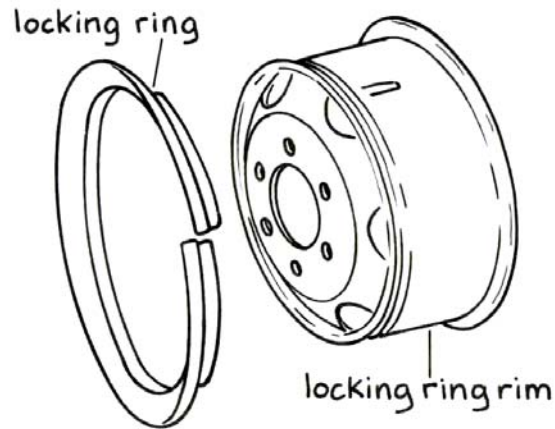
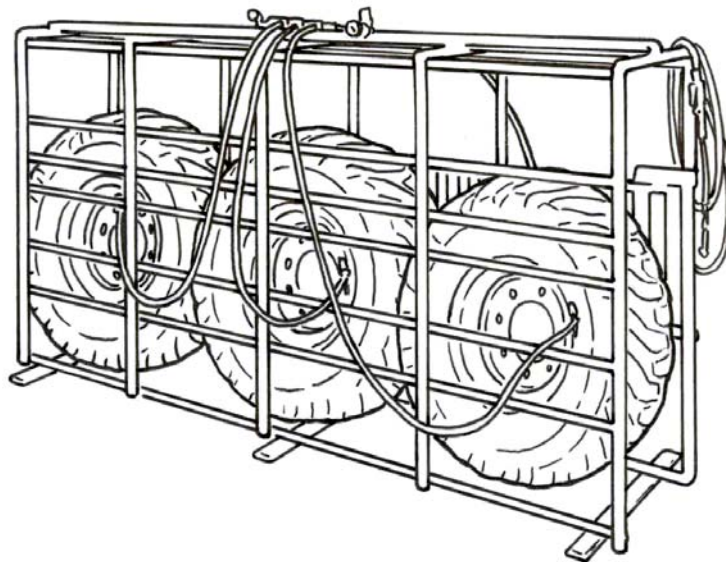

Figure 2 Example of cage used to restrain split rim wheel assemblies



When inflating split rim and locking ring wheels, only a clamp-on type connector is allowed. A clamp-on type connector attaches securely to the valve stem and does not require the worker to hold it in place against the valve during inflation (see Figure 3). This allows the worker to inflate the tire while standing a safe distance away from the tire.

When inflating split rim and locking ring wheels, only a clamp-on type connector is allowed.

Figure 3 Clamp-on connector

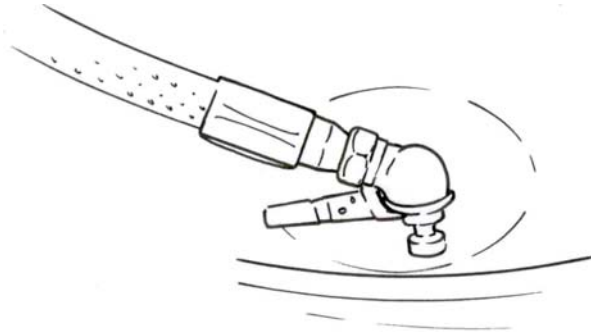

Other types of inflation devices usually require the worker to forcibly hold them against the tire's valve stem, requiring the worker to stand immediately next to the wheel. Such inflation devices are unacceptable because their use places the worker at risk of serious injury in the event of a blowoff or other tire failure.

The use of connectors that are the non clamp-on type places the worker at risk of serious injury in the event of a blowoff or other tire failure.

When a clamp-on air connector is used to inflate a tire, the inflation hose to which it is attached must

- (a) *permit the use of an in-line pressure gauge* – this eliminates the need for the worker to approach the tire to take a pressure reading with a pencil-type pressure gauge. The pressure gauge can be built directly into the inflation control or the control may have a check valve that allows pressures to be measured using a pencil-type pressure gauge (see Figure 4). The worker must be able to monitor tire pressure at a safe distance away from the tire being inflated, and
- (b) *be under positive pressure control by the worker filling the tire* – air can only be delivered to the tire while the worker squeezes or depresses a control. The flow of air must stop immediately upon the worker releasing the control.

Figure 4 In-line valve and gauge

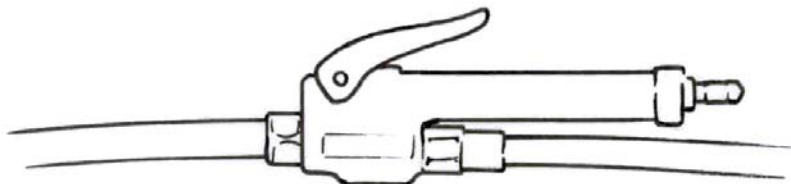

The worker is responsible for staying in a safe position while inflating a tire. Figure 5 shows examples of the trajectories a wheel assembly might take if it should separate. The hose should be long enough between the clamp-on connector and the in-line valve to allow the worker to stand in a safe position.

The worker is responsible for staying in a safe position while inflating a tire.

Figure 5 Examples of trajectories and dangerous work positions

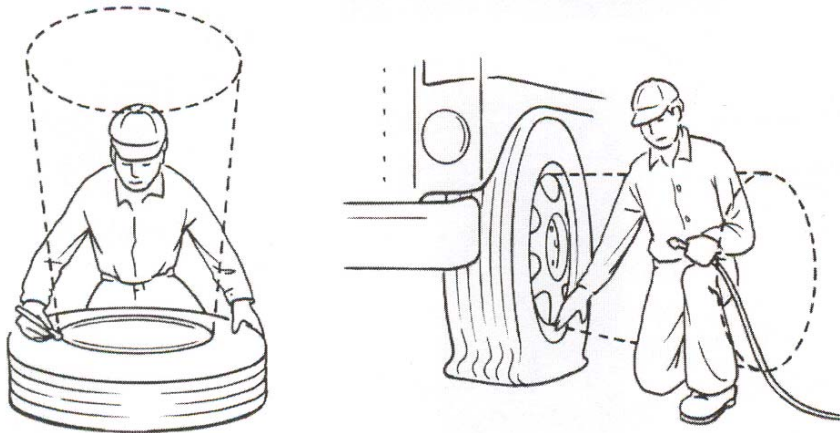

Large vehicle tire and wheel assemblies

Many large vehicles such as trucks, tractors, trailers, buses and off-road machines do not use split-rim or locking ring wheel assemblies. However, manufacturers of the tire and wheel assemblies used with these vehicles require that the wheels be inflated in a safety cage or be restrained to contain flying parts in the event of tire rupture or component failure. Always refer to the manufacturer's specifications and manuals for information about how to service these tire and wheel assemblies and follow the recommended practices.

Servicing and inflating tire and wheel assemblies used on pick-up trucks, vans and automobiles does not normally require the use of a tire cage. Refer to the manufacturer's specifications and manuals for information about how to service these tire and wheel assemblies.

Recommended practices

In addition to complying with the rules specified in the *OHS Code*, the following safe work practices should also be followed:

- Follow the manufacturer's specification for tire and rim servicing.
- Do not attempt to seat rim components by hammering on them when the tire is inflated or partially inflated.
- Never introduce a flammable substance such as ether into a tire (to help in seating the tire bead).
- Do not overload or over-inflate a tire.
- Match tires with rims of the appropriate size.
- With split rims, make sure that parts match. The numbers stamped into the rim must match those stamped into the locking rings. If the numbers are not legible or do not match, the parts must not be used.
- Rim components should never be modified or welded.

For more information

 www.gov.ab.ca/hre/whs/publications/pdf/OHSC-1.pdf
Occupational Health and Safety Code

 www.gov.ab.ca/hre/whs/law/ohs_regcode_down.asp#eg
Occupational Health and Safety Code Explanation Guide

 www.wcb.nt.ca/PDF%20Files/TireHazard.pdf
Hazard Alert – Split Rim Tires; WCB of Northwest Territories and Nunavut

 www.cdc.gov/niosh/nasd/docs/pdfs/oa04700.pdf
Servicing Multi-Piece and Single Piece Rim Wheels:
OHS Standard 1919.177

Fatality reports

 www.gov.ab.ca/hre/whs/fatalities/pdf/FR-2000-09-15b.pdf
Worker Struck by Tire Rim – September 15, 2000

 www.gov.ab.ca/hre/whs/fatalities/pdf/FR-1998-06-27.pdf
Worker Struck by Truck Wheel – June 27, 1998

Contact us:

Province-Wide Contact Centre

 Edmonton & surrounding area:
(780) 415-8690

 Toll-free within Alberta:
1-866-415-8690



Deaf or hearing impaired

- In Edmonton: **(780) 427-9999**

or

- **1-800-232-7215** throughout Alberta

Web Site



www.worksafely.org

Getting copies of OHS Act, Regulation & Code:

Queen's Printer



www.qp.gov.ab.ca



Edmonton (780) 427-4952
Calgary (403) 297-6251

Workplace Health and Safety



www.whs.gov.ab.ca/law

Call any Government of Alberta office toll-free
Dial 310-0000, then the area code and telephone number you want to reach

© 2003-2004, Government of Alberta, Human Resources and Employment

This material may be used, reproduced, stored or transmitted for non-commercial purposes. The source of this material must be acknowledged when publishing or issuing it to others. This material is not to be used, reproduced, stored or transmitted for commercial purposes without written permission from the Government of Alberta, Human Resources and Employment. This material is to be used for information purposes only no warranty express or implied is given as to the accuracy or the timeliness of the material presented.